

ژنراتور : Stamford

موتور دیزل : Cummins

Standby		Prime		دیزل ژنراتور
KVA	KW	KVA	KW	
313	250	275	220	

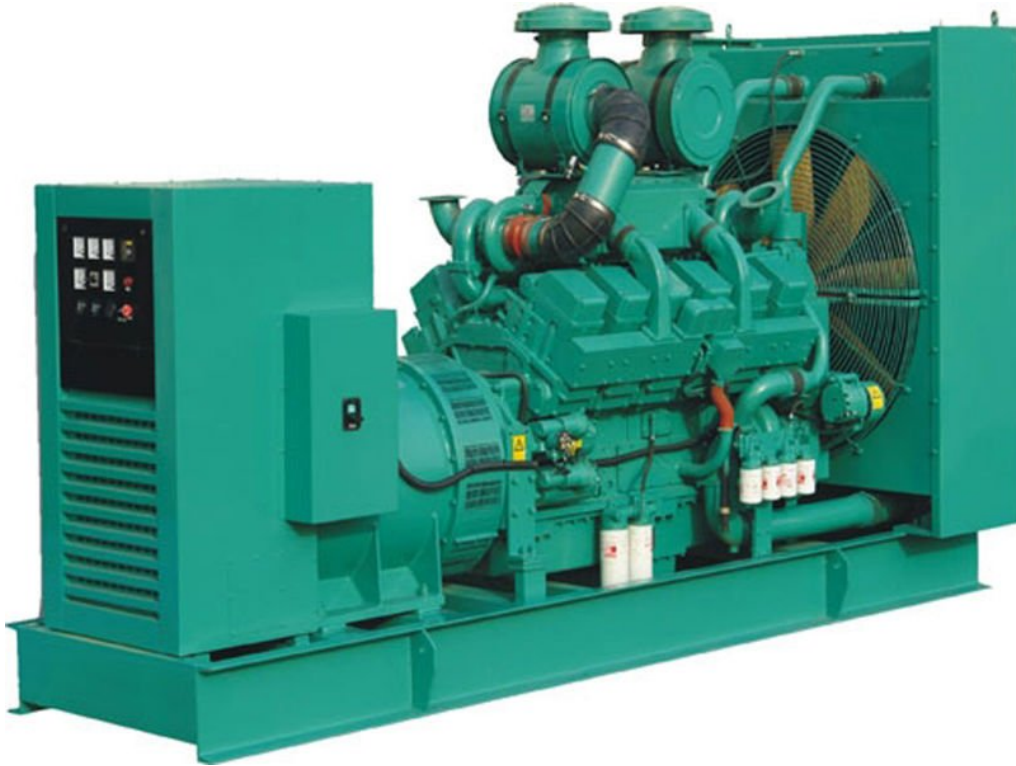

موتور دیزل		
Manufacturer	Cummins	تولید کننده
Type	NTA855G1A	تیپ
Number of cylinders	6	تعداد سیلندر ها
Cylinder arrangement	Vertical in-line	آرایش سیلندر ها
Displacement , Liters	14	جا به جایی
Bore × Stroke , mm	140 X 152	قطر سیلندر × کورس پیستون
Compression Ratio	14.5 : 1	نسبت تراکم
Aspiration	Turbocharged	سیستم تنفس
Gross engine power, kWb	220	قدرت نافالص موتور
Combustion air flow, L/sec	353	جریان هوای احتراق
Exhaust gas temp.(after turbo) , °C	484	دمای گاز خروجی از اگزوز
Mean Piston Speed , m/s	7.62	میانگین سرعت پیستون

ژنراتور		
Manufacturer	Stamford	تولید کننده
Type	HCI 444D	تیپ
Standby power at rated voltage ,KVA	313	توان standby در ولتاژ نامی
Efficiency, %	93.3	راندمان
Power factor	0.8	ضریب قدرت
Phase	3	فاز
Frequency, Hz	50	فرکانس
Speed, Rpm	1500	سرعت
Voltage, V	380	ولتاژ
Stator windings	Double layer concentric	سیم پیچ استاتور
Voltage Regulation, %	± % 1.0	تنظیم ولتاژ
Over speed, Rpm	2250	مداکثر سرعت مجاز
Short circuit ratio	1/Xd	جریان اتصال کوتاه
Insulation class	H	کلاس عایق
Protection class	IP23	کلاس حفاظتی
Cooling air volume,m <sup>3</sup> / sec	0.486	دبی هوای فنک کننده

## Engine Data Sheet

**MODEL: NTA855-G1A**  
**CONFIGURATION NO.: D092473DX02**  
**CPL NUMBER: CQ103**

**DATA SHEET: DS-172E**  
**PERFORMANCE CURVE: C-172E**  
**INSTALLATION DIAGRAM: 4061365**

**PRIME POWER: 350 HP (261 kW) at 1500 r/min**  
**STANDBY POWER: 390 HP (291 kW) at 1500 r/min**

**DATE: 2006-9-22**  
**REVISION: 04**

### GENERAL ENGINE DATA

Type.....	4-Cycle;In-line;6-Cylinder
Aspiration .....	Turbocharged,Aftercooled
Bore x Stroke - in.×in. (mm×mm).....	5.5.×6 ( 140 × 152 )
Displacement - in. <sup>3</sup> (L).....	855 ( 14 )
Compression Ratio .....	14.5:1
Firing Order .....	1-5-3-6-2-4

#### Dry Weight

--Fan to Flywheel Engine - lb. (kg).....	2870.....( 1300 )
--Heat Exchanger Cooled Engine - lb. (kg).....	3095.....( 1410 )

#### Wet Weight

--Fan to Flywheel Engine - lb. (kg).....	2970.....( 1350 )
--Heat Exchanger Cooled Engine - lb. (kg).....	3320.....( 1510 )

Moment of Inertia of Rotating Components - With FW1109 flywheel - lb.·ft. <sup>2</sup> (kg·m	118.5 ( 4.99 )
Center of Gravity from Rear Face of Flywheel Housing - in.(mm) .....	27.7 ( 704 )
Center of Gravity Above Crankshaft Centerline - in.(mm) .....	5.5 ( 140 )

### ENGINE MOUNTING

Maximum Allowable Bending Moment at Rear Face of Block - lb.·ft. (N·m).....	1000.. ( 1356 )
---	-----------------

### EXHAUST SYSTEM

Maximum Allowable Back Pressure - in.Hg (kPa).....	3.0 ( 10 )
Standard Exhaust Pipe Diameter - in. (mm).....	5.0 ( 127 )

### AIR INDUCTION SYSTEM

Maximum Allowable Intake Air Restriction	
--With Clean Filter Element - in. H <sub>2</sub> O (kPa).....	15..... ( 3.74 )
--With Dirty Filter Element - in. H <sub>2</sub> O (kPa) .....	25. ( 6.22 )
Minimum Dirt Holding Capacity - g/CFM ( g/L/s ).....	25 ( 53 )
Maximum Allowable Intake Air Temperature ΔT - °F (°C).....	30..... ( 17 )

### COOLING SYSTEM

Coolant Capacity - Engine Only - U.S. gal (L).....	5.5..... ( 20.8 )
- With Radiator - U.S. gal (L).....	16.0 ( 60.6 )
- With Heat Exchanger - U.S. gal (L).....	13.0 ( 49.2 )
Maximum Coolant Friction Head External to Engine - PSI (kPa).....	6... ( 41 )
Maximum Static Head of Coolant (exclusive of Pressure Cap) - PSI (kPa) .....	15..... ( 103 )
Maximum Static Head of Coolant Above Engine Crank Centerline -ft. (m) .....	46..... ( 14.0 )
Standard Thermostat (Modulating) Range - °F (°C) .....	180.- 202 ( 82 - 94 )
Minimum Allowable Pressure Cap -PSI (kPa).....	7.0.....( 48.2 )
Maximum Coolant Temperature - °F (°C).....	205 ( 96 )
Maximum Top Tank Temperature - °F (°C).....	212. ( 100 )
Minimum Top Tank Temperature - °F (°C).....	160 ( 71 )
Maximum Allowable Top Tank Temperature for Standby / Prime Power - °F (°C)....	220./ 212.....( 104./ 100.).....
Minimum Recommended Top Tank Temperature - °F (°C).....	160.....( 71.)

Minimum Coolant Expansion Space - % of System Capacity .....	5	
Minimum Coolant Makeup Capacity - U.S. gal (L).....	1.1	( 4.2 )
Maximum Raw Water Pressure at Engine Outlet -PSI (kPa).....	15	( 103 )
Maximum Inlet Restriction at Raw Water Pump - in.Hg (kPa).....	10	( 34 )
Maximum Raw Water Pump Initial Suction Lift- ft. (m).....	3.05	( 10 )
Minimum Raw Water Pipe Size - in. (mm).....	2	( 51 )
Allowable Pressure Drop Across Keel Cooler -PSI (kPa).....	4	( 28 )

### LUBRICATION SYSTEM

Oil Pressure @ Idle Speed - PSI (kPa).....	15 Min	( 103 ) Min
@ Governed Speed - PSI (kPa).....	35-50	( 241 - 345 )
Maximum Allowable Oil Temperature - °F (°C).....	250	( 121 )
Maximum Oil Consumption - U.S.qt./h (L/h).....	0.25	( 0.24 )
Oil Pan Capacity - Low / High - U.S. gal. (L).....	7.5 / 9.5	( 28.4 / 36.0 )
Total System Capacity - U.S. gal. (L).....	10.2	( 38.6 )
Angularity of Oil Pan - Front Down/Front Up/Side to Side.....	38°/38°/38°	

### FUEL SYSTEM

Type Injection System.....	Direct Injection Cummins PT	
Maximum Allowable Restriction to Fuel Pump		
-- With Clean Fuel Filter - in.Hg (kPa).....	4.0	( 13.5 )
-- With Dirty Fuel Filter - in.Hg (kPa).....	8.0	( 27.1 )
Maximum Allowable Head on Injector Return Line		
-- With Check Valve - in.Hg (kPa).....	6.5	( 22.0 )
-- Without Check Valve - in.Hg (kPa).....	2.5	( 8.5 )
Minimum Fuel Supply Line Size - in. (mm).....	0.625	( 16 )
Minimum Fuel Return Line Size - in. (mm).....	0.5	( 13 )
Maximum Fuel Pump Supply - U.S.gal/h (L).....	71	( 270 )
Fuel Rail Pressure - PSI (kPa).....	201	( 1382.5 )
Maximum Fuel Temperature °F (°C).....	160	( 71 )

### ELECTRICAL SYSTEM

Minimum Recommended Battery Capacity ( 24V )		
-- Cold Soak (No Load) - CCA.....	900	
- Minimum Reserved Capacity - CCA.....	320	
-- Cold Soak (With Load) - CCA.....	900	
- Minimum Reserved Capacity - CCA.....	320	
Maximum Allowable Resistance of Cranking Circuit - ohm.....	0.002	
Standard Cranking Motor (Heavy Duty , Positive Engagement) - volt.....	24	
Standard Battery Charging System , Negative Ground - ampere.....	35	

### PERFORMANCE DATA

Idle Speed - r/min .....	575 - 650	
Maximum No-Load Governed Speed - r/min .....	1800	
Maximum over Speed Capability - r/min .....	2700	
Minimum Crankshaft Rotation for unaided Cold Start - r/min.....	150	
Minimum Torque for unaided Cold Start - lb.ft. (N·m).....	375	( 509 )
Exhaust Sound Pressure at 1m from Exhaust Outlet -1500r/min -dBA.....	N/A	

All data is based on :

--Engine Operating with fuel system, water pump, lubricating oil pump, air cleaner and exhaust silencer, fan, and optional driven components.

--Engine operating with fuel corresponding to grade No.2-D per **ASTM D975**.

--**ISO 3046**, Part1, Standard Reference Conditions of : Barometric Pressure:100kPa(29.5in.Hg); Altitude: 110m (361ft.); Air Temperature: 25°C (77°F) ; Relative Humidity: 30% .

--This Data Sheet includes both air-cooled (Fan/Radiator) & raw water cooled (Heatexchanger/Raw Water Pump) type engine.

	Rated Condition		Max Condition	
	50Hz		50Hz	
	1500		1500	
Governed Engine Speed - r/min.....	1500		1500	
Gross Engine Power Output - HP (kW) .....	350	(261)	390	(291)
Torque lb.-ft. (N·m).....	1226	(1662)	1367	(1853)
Brake Mean Effective Pressure - PSI (kPa) .....	216	(1491)	241	(1663)
Piston Speed - ft./min (m/s).....	1500	(7.62)	1500	(7.62)
Friction Horsepower - HP (kW).....	30	(22)	30	(22)
Intake Air Flow - CFM (L/s) .....	747	(353)	802	(379)
Engine Water Flow - GPM (L/min.) .....	79	(5)	79	(5)
Raw Water Flow - GPM (L/s) .....	54	(3.4)	54	(3.4)
Fuel Consumption - U.S.gal/h (L/h).....	16.2	(61)	18.0	(68)
Oil Flow - GPM (L/s) .....	35	(2.2)	35	(2.2)
Exhaust Gas Temperature (After Turbine) - °F (°C).....	904	(484)	928	(498)
Exhaust Gas Flow (After Turbine) - CFM (L/s).....	1751	(826)	1984	(936)
Air to Fuel Ratio.....	27.3 : 1		26.3 : 1	
Heat Radiation - BTU (kW).....	1860	(33)	2070	(36)
Heat Rejection to Coolant - BTU (kW).....	11140	(196)	12420	(218)
Heat Rejection to Ambient - BTU (kW).....	9290	(163)	10350	(182)

Engine Model: NTA855-G1A

Data Sheet: DS-172E

Date: 2006-9-22

## CHONGQING CUMMINS ENGINE CO. LTD.

All Data is Subject to Change Without Notice - contact CCEC for most recent data

## HCI 434D/444D - Technical Data Sheet

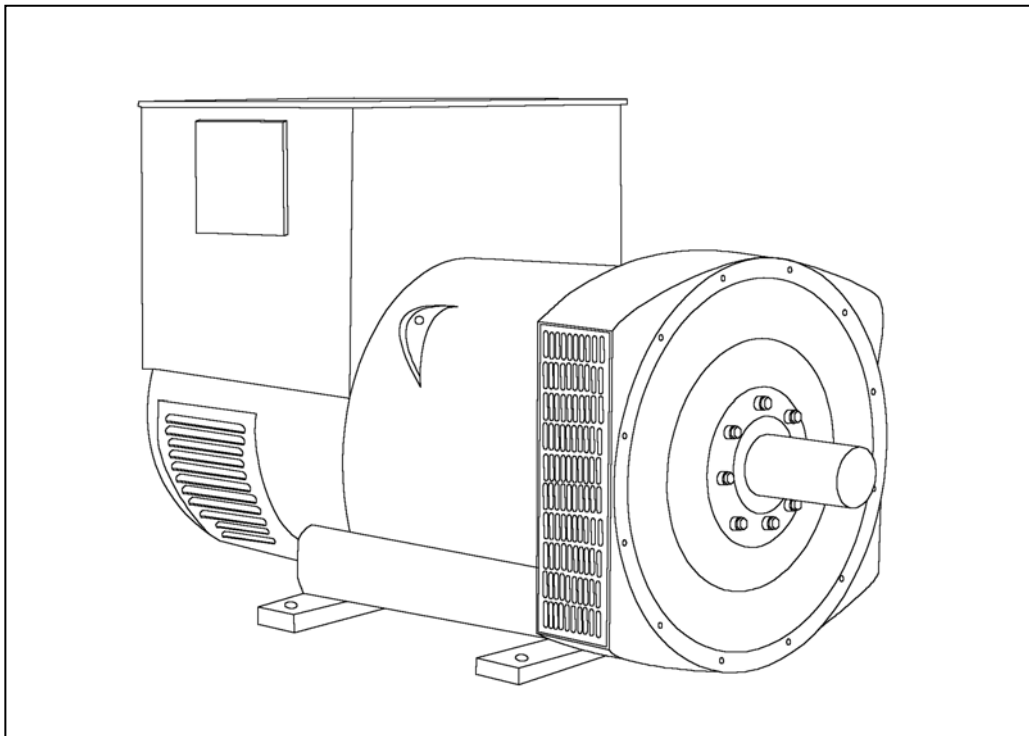

# HCI434D/444D

## SPECIFICATIONS & OPTIONS



### STANDARDS

Newage Stamford industrial generators meet the requirements of BS EN 60034 and the relevant section of other international standards such as BS5000, VDE 0530, NEMA MG1-32, IEC34, CSA C22.2-100, AS1359. Other standards and certifications can be considered on request.

### VOLTAGE REGULATORS

#### SX440 AVR - STANDARD

With this self-excited system the main stator provides power via the Automatic Voltage Regulator (AVR) to the exciter stator. The high efficiency semi-conductors of the AVR ensure positive build-up from initial low levels of residual voltage.

The exciter rotor output is fed to the main rotor through a three-phase full-wave bridge rectifier. The rectifier is protected by a surge suppressor against surges caused, for example, by short circuit or out-of-phase paralleling.

The SX440 will support a range of electronic accessories, including a 'droop' Current Transformer (CT) to permit parallel operation with other ac generators.

If 3-phase sensing is required with the self-excited system, the SX421 AVR must be used.

#### SX421 AVR

This AVR also operates in a self-excited system. It combines all the features of the SX440 with, additionally, three-phase rms sensing for improved regulation and performance. Over voltage protection is provided via a separate circuit breaker. An engine relief load acceptance feature is built in as standard.

#### MX341 AVR

This sophisticated AVR is incorporated into the Stamford Permanent Magnet Generator (PMG) control system.

The PMG provides power via the AVR to the main exciter, giving a source of constant excitation power independent of generator output. The main exciter output is then fed to the main rotor, through a full wave bridge, protected by a surge suppressor. The AVR has in-built protection against sustained over-excitation, caused by internal or external faults. This de-excites the machine after a minimum of 5 seconds.

An engine relief load acceptance feature can enable full load to be applied to the generator in a single step.

If three-phase sensing is required with the PMG system the MX321 AVR must be used.

We recommend three-phase sensing for applications with greatly unbalanced or highly non-linear loads.

#### MX321 AVR

The most sophisticated of all our AVRs combines all the features of the MX341 with, additionally, three-phase rms sensing, for improved regulation and performance.

Over voltage protection is built-in and short circuit current level adjustments is an optional facility.

### WINDINGS & ELECTRICAL PERFORMANCE

All generator stators are wound to 2/3 pitch. This eliminates triplen (3rd, 9th, 15th ...) harmonics on the voltage waveform and is found to be the optimum design for trouble-free supply of non-linear loads. The 2/3 pitch design avoids excessive neutral currents sometimes seen with higher winding pitches, when in parallel with the mains. A fully connected damper winding reduces oscillations during paralleling. This winding, with the 2/3 pitch and carefully selected pole and tooth designs, ensures very low waveform distortion.

### TERMINALS & TERMINAL BOX

Standard generators are 3-phase reconnectable with 12 ends brought out to the terminals, which are mounted on a cover at the non-drive end of the generator. A sheet steel terminal box contains the AVR and provides ample space for the customers' wiring and gland arrangements. It has removable panels for easy access.

### SHAFT & KEYS

All generator rotors are dynamically balanced to better than BS6861:Part 1 Grade 2.5 for minimum vibration in operation. Two bearing generators are balanced with a half key.

### INSULATION/IMPREGNATION

The insulation system is class 'H'.

All wound components are impregnated with materials and processes designed specifically to provide the high build required for static windings and the high mechanical strength required for rotating components.

### QUALITY ASSURANCE

Generators are manufactured using production procedures having a quality assurance level to BS EN ISO 9001.

The stated voltage regulation may not be maintained in the presence of certain radio transmitted signals. Any change in performance will fall within the limits of Criteria 'B' of EN 61000-6-2:2001. At no time will the steady-state voltage regulation exceed 2%.

*NB Continuous development of our products entitles us to change specification details without notice, therefore they must not be regarded as binding.*

*Front cover drawing typical of product range.*



**HCI434D/444D**

**WINDING 311**

CONTROL SYSTEM	SEPARATELY EXCITED BY P.M.G.							
A.V.R.	MX321	MX341						
VOLTAGE REGULATION	± 0.5 %	± 1.0 %	With 4% ENGINE GOVERNING					
SUSTAINED SHORT CIRCUIT	REFER TO SHORT CIRCUIT DECREMENT CURVES (page 7)							
CONTROL SYSTEM	SELF EXCITED							
A.V.R.	SX440	SX421						
VOLTAGE REGULATION	± 1.0 %	± 0.5 %	With 4% ENGINE GOVERNING					
SUSTAINED SHORT CIRCUIT	WILL NOT SUSTAIN A SHORT CIRCUIT							
INSULATION SYSTEM	CLASS H							
PROTECTION	IP23							
RATED POWER FACTOR	0.8							
STATOR WINDING	DOUBLE LAYER LAP							
WINDING PITCH	TWO THIRDS							
WINDING LEADS	12							
STATOR WDG. RESISTANCE	0.0124 Ohms PER PHASE AT 22°C SERIES STAR CONNECTED							
ROTOR WDG. RESISTANCE	1.05 Ohms at 22°C							
R.F.I. SUPPRESSION	BS EN 61000-6-2 & BS EN 61000-6-4,VDE 0875G, VDE 0875N. refer to factory for others							
WAVEFORM DISTORTION	NO LOAD < 1.5% NON-DISTORTING BALANCED LINEAR LOAD < 5.0%							
MAXIMUM OVERSPEED	2250 Rev/Min							
BEARING DRIVE END	BALL. 6317 (ISO)							
BEARING NON-DRIVE END	BALL. 6314 (ISO)							
	1 BEARING				2 BEARING			
WEIGHT COMP. GENERATOR	940 kg				950 kg			
WEIGHT WOUND STATOR	415 kg				415 kg			
WEIGHT WOUND ROTOR	361 kg				338 kg			
WR <sup>2</sup> INERTIA	4.0771 kgm <sup>2</sup>				3.8783 kgm <sup>2</sup>			
SHIPPING WEIGHTS in a crate	1010 kg				1010 kg			
PACKING CRATE SIZE	155 x 87 x 107(cm)				156 x 87 x 107(cm)			
	50 Hz				60 Hz			
TELEPHONE INTERFERENCE	THF<2%				TIF<50			
COOLING AIR	0.486 m <sup>3</sup> /sec 1030 cfm				0.580 m <sup>3</sup> /sec 1240 cfm			
VOLTAGE SERIES STAR	380/220	400/231	415/240	440/254	416/240	440/254	460/266	480/277
VOLTAGE PARALLEL STAR	190/110	200/115	208/120	220/127	208/120	220/127	230/133	240/138
VOLTAGE SERIES DELTA	220/110	230/115	240/120	254/127	240/120	254/127	266/133	277/138
KVA BASE RATING FOR REACTANCE VALUES	295	295	295	280	338	350	363	375
X <sub>d</sub> DIR. AXIS SYNCHRONOUS	3.11	2.81	2.61	2.20	3.54	3.28	3.11	2.95
X' <sub>d</sub> DIR. AXIS TRANSIENT	0.20	0.18	0.17	0.14	0.22	0.20	0.19	0.18
X'' <sub>d</sub> DIR. AXIS SUBTRANSIENT	0.14	0.13	0.12	0.10	0.15	0.14	0.13	0.13
X <sub>q</sub> QUAD. AXIS REACTANCE	2.61	2.36	2.19	1.85	3.03	2.80	2.66	2.53
X'' <sub>q</sub> QUAD. AXIS SUBTRANSIENT	0.38	0.34	0.32	0.27	0.40	0.37	0.35	0.33
X <sub>L</sub> LEAKAGE REACTANCE	0.07	0.06	0.06	0.05	0.09	0.08	0.08	0.08
X <sub>2</sub> NEGATIVE SEQUENCE	0.26	0.24	0.22	0.19	0.28	0.26	0.25	0.23
X <sub>0</sub> ZERO SEQUENCE	0.10	0.09	0.08	0.07	0.10	0.09	0.09	0.08
REACTANCES ARE SATURATED VALUES ARE PER UNIT AT RATING AND VOLTAGE INDICATED								
T' <sub>d</sub> TRANSIENT TIME CONST.	0.08s							
T'' <sub>d</sub> SUB-TRANSTIME CONST.	0.019s							
T' <sub>do</sub> O.C. FIELD TIME CONST.	1.7s							
T <sub>a</sub> ARMATURE TIME CONST.	0.018s							
SHORT CIRCUIT RATIO	1/X <sub>d</sub>							

**50  
Hz**

**HCI434D/444D**  
Winding 311



**THREE PHASE EFFICIENCY CURVES**

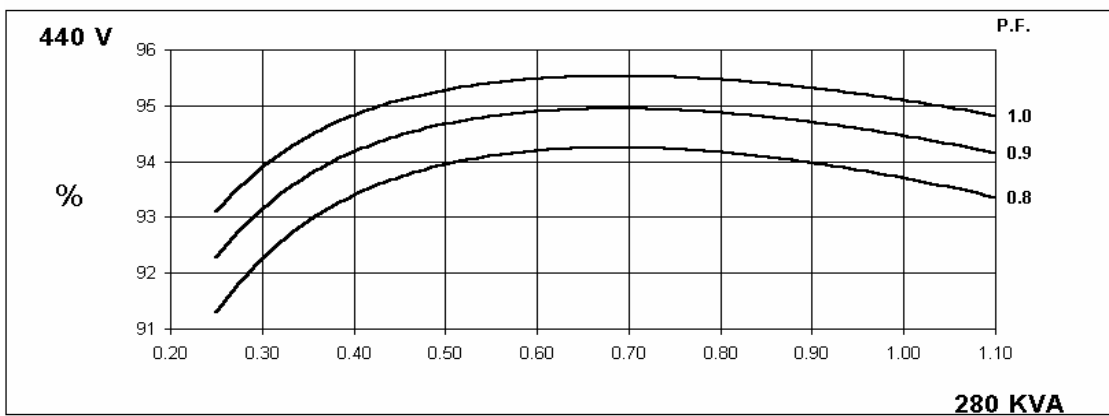
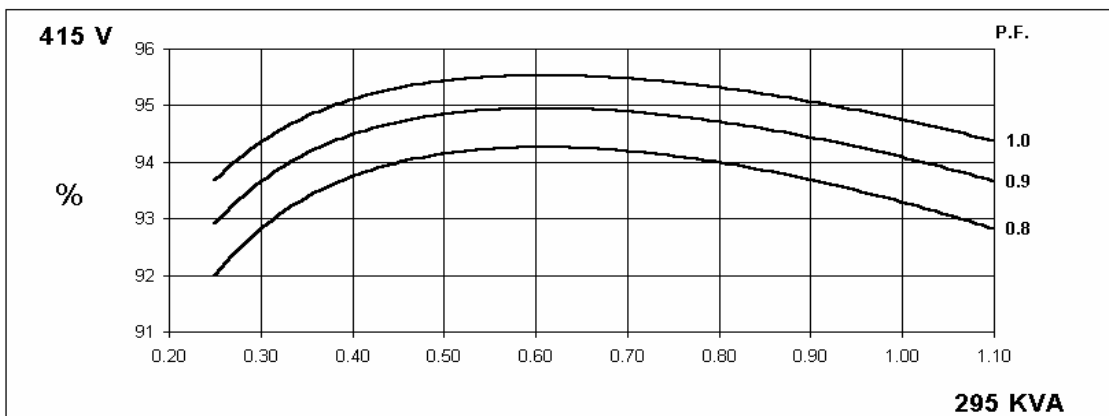
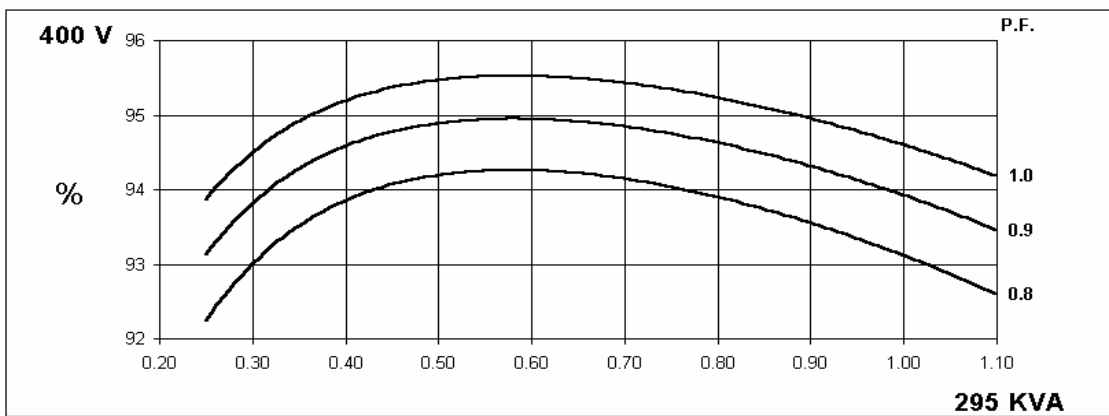
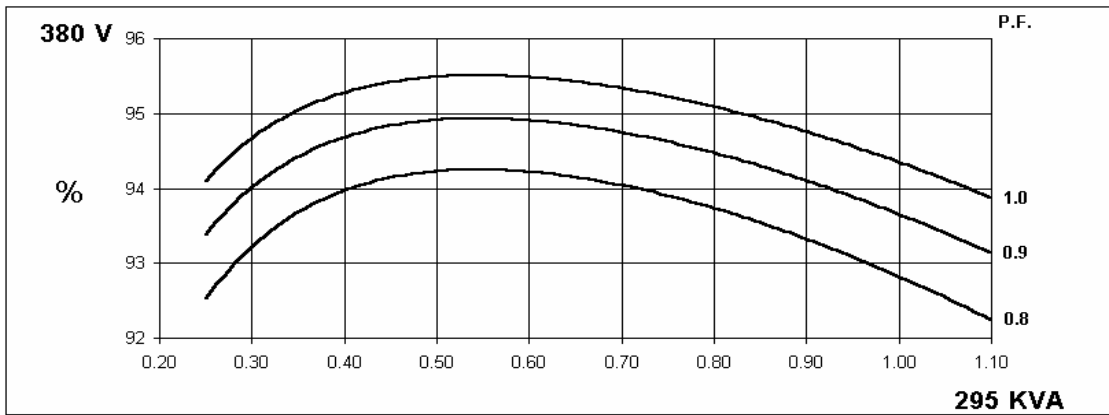

**THREE PHASE EFFICIENCY CURVES**

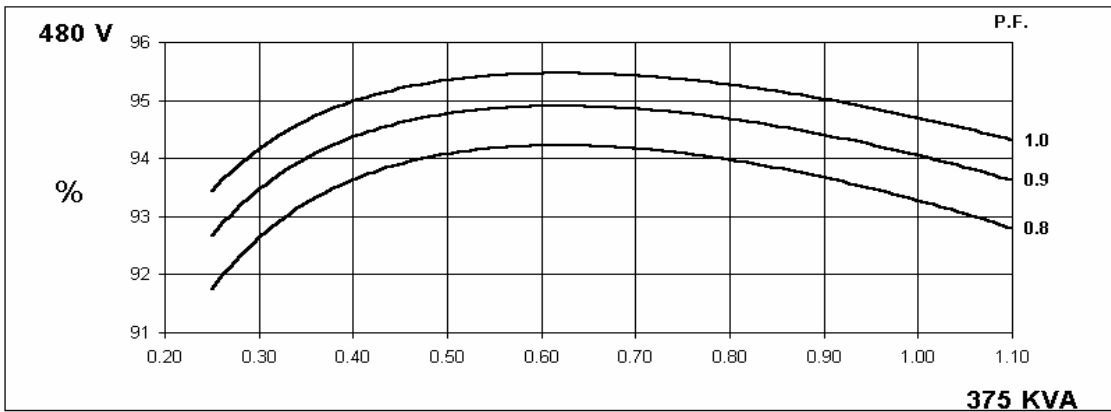
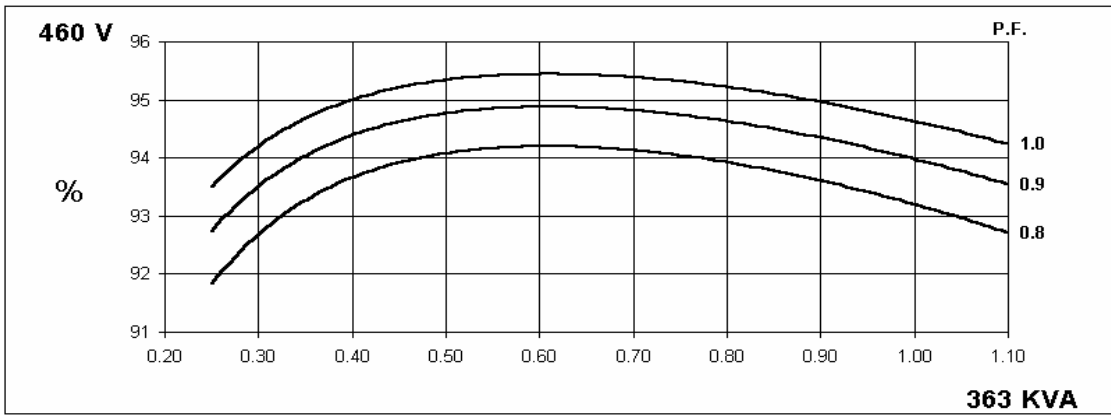
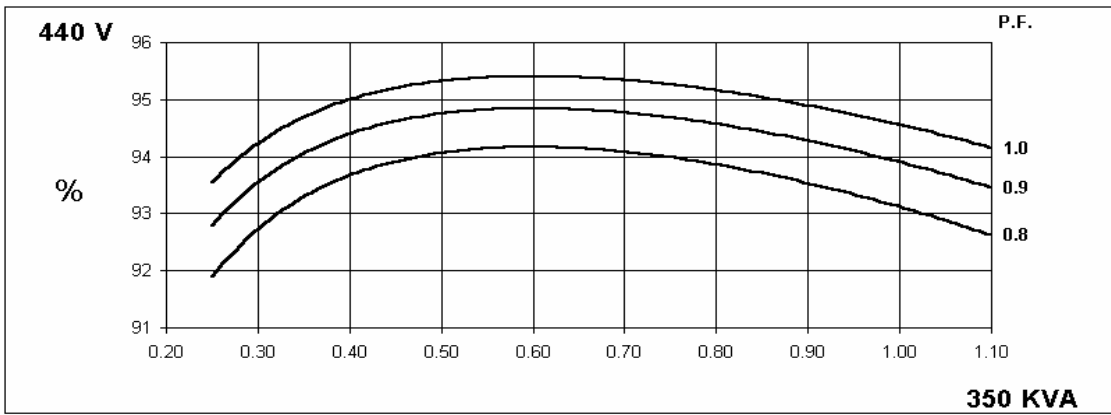
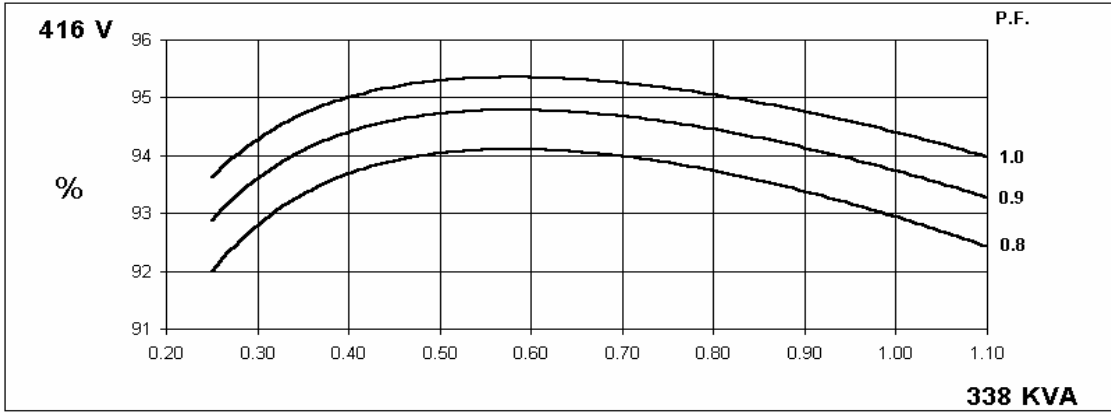

# HCI434D/444D

Winding 311



## Locked Rotor Motor Starting Curve

**50  
Hz**

**MX**

**SX**

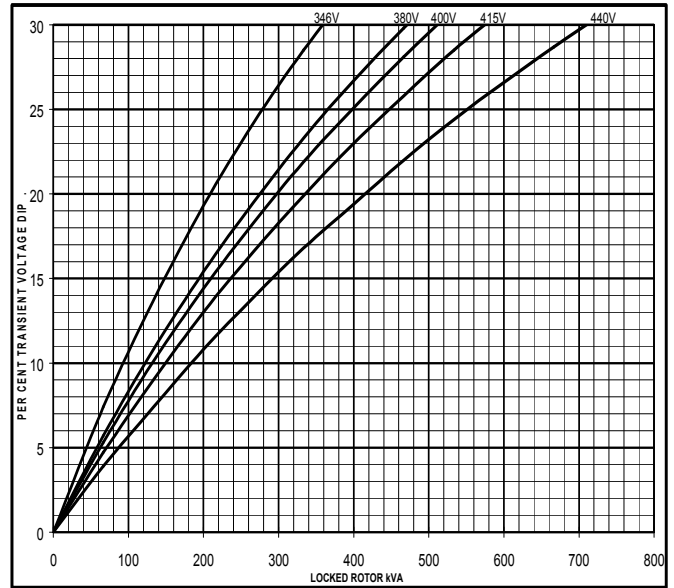
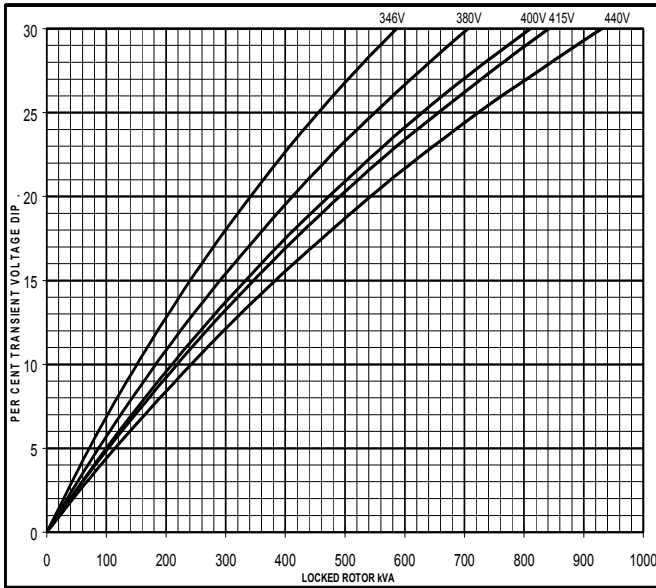

**60  
Hz**

**MX**

**SX**

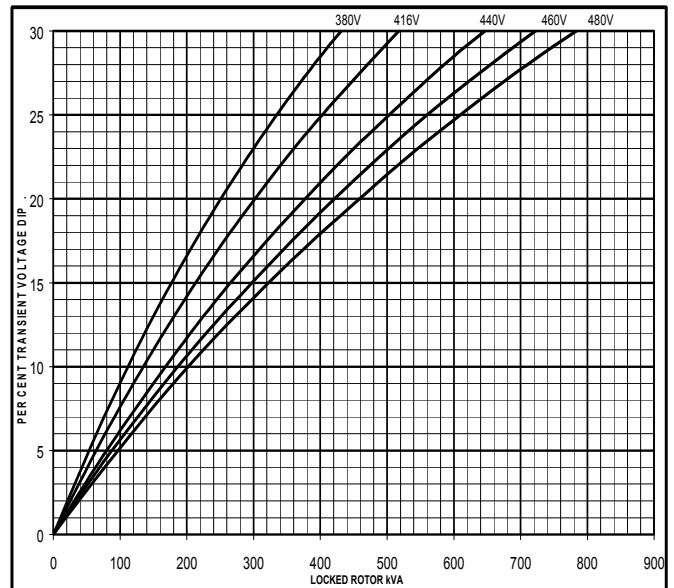
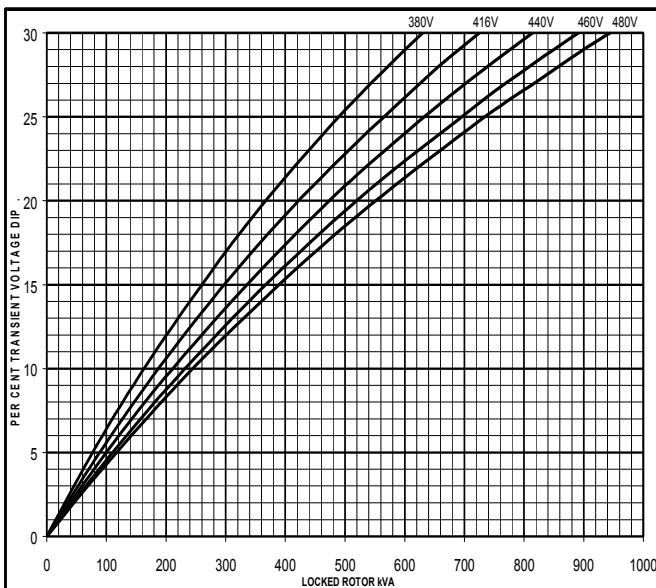

**Three-phase Short Circuit Decrement Curve. No-load Excitation at Rated Speed  
Based on star (wye) connection.**

**50  
Hz**

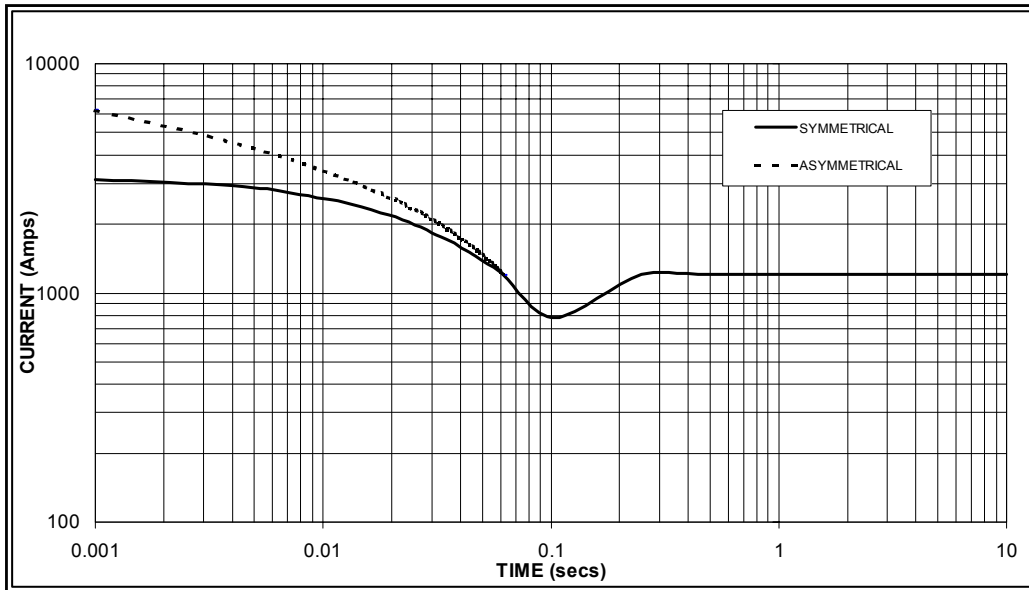

Sustained Short Circuit = 1,300 Amps

**60  
Hz**

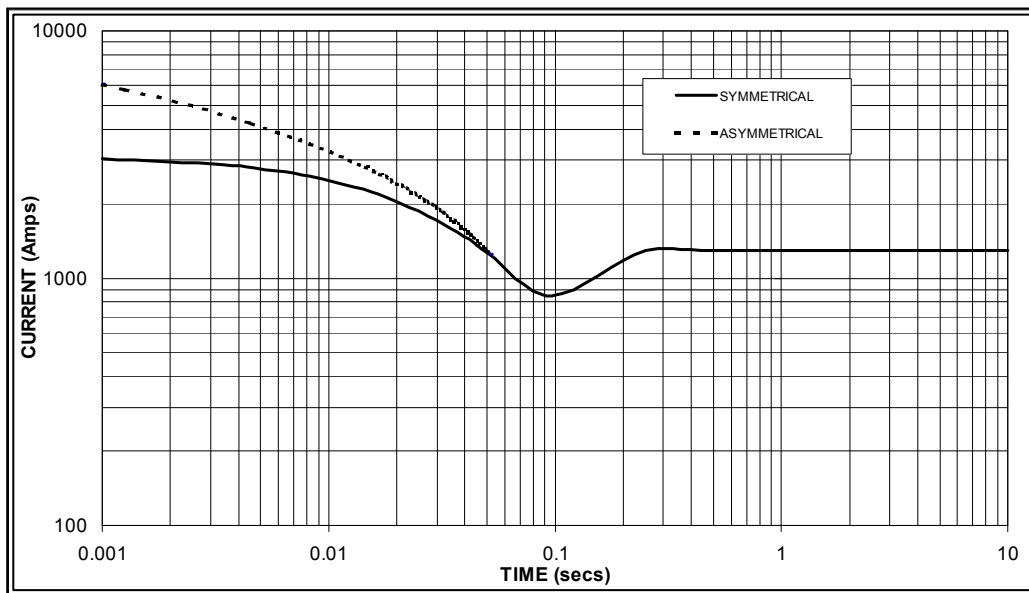

Sustained Short Circuit = 1,200 Amps

**Note 1**

The following multiplication factors should be used to adjust the values from curve between time 0.001 seconds and the minimum current point in respect of nominal operating voltage :

50Hz		60Hz	
Voltage	Factor	Voltage	Factor
380v	X 1.00	416v	X 1.00
400v	X 1.05	440v	X 1.06
415v	X 1.09	460v	X 1.10
440v	X 1.16	480v	X 1.15

The sustained current value is constant irrespective of voltage level

**Note 2**

The following multiplication factor should be used to convert the values calculated in accordance with NOTE 1 to those applicable to the various types of short circuit :

	3-phase	2-phase L-L	1-phase L-N
Instantaneous	x 1.00	x 0.87	x 1.30
Minimum	x 1.00	x 1.80	x 3.20
Sustained	x 1.00	x 1.50	x 2.50
Max. sustained duration	10 sec.	5 sec.	2 sec.

All other times are unchanged

**Note 3**

Curves are drawn for Star (Wye) connected machines. For other connection the following multipliers should be applied to current values as shown :

Parallel Star = Curve current value X 2

Series Delta = Curve current value X 1.732

# HCI434D/444D

## Winding 311 / 0.8 Power Factor



### RATINGS

Class - Temp Rise	Cont. F - 105/40°C				Cont. H - 125/40°C				Standby - 150/40°C				Standby - 163/27°C				
<b>50 Hz</b>	Series Star (V)	380	400	415	440	380	400	415	440	380	400	415	440	380	400	415	440
	Parallel Star (V)	190	200	208	220	190	200	208	220	190	200	208	220	190	200	208	220
	Series Delta (V)	220	230	240	254	220	230	240	254	220	230	240	254	220	230	240	254
kVA	268	268	268	255	295	295	295	280	313	313	313	295	323	323	323	305	
kW	214	214	214	204	236	236	236	224	250	250	250	236	258	258	258	244	
Efficiency (%)	93.3	93.5	93.7	94.0	92.8	93.1	93.3	93.7	92.5	92.8	93.0	93.5	92.3	92.6	92.8	93.4	
kW Input	230	229	229	217	254	253	253	239	271	270	269	252	280	279	278	261	

<b>60 Hz</b>	Series Star (V)	416	440	460	480	416	440	460	480	416	440	460	480	416	440	460	480
	Parallel Star (V)	208	220	230	240	208	220	230	240	208	220	230	240	208	220	230	240
	Delta (V)	240	254	266	277	240	254	266	277	240	254	266	277	240	254	266	277
kVA	305	315	330	340	338	350	363	375	356	375	388	400	363	383	398	413	
kW	244	252	264	272	270	280	290	300	285	300	310	320	290	306	318	330	
Efficiency (%)	93.4	93.5	93.6	93.7	92.9	93.1	93.2	93.3	92.7	92.8	92.9	93.0	92.6	92.7	92.7	92.8	
kW Input	261	270	282	290	291	301	312	322	307	323	334	344	314	331	343	356	

### DIMENSIONS

